

Dress-Skirt

From a Vintage Lacy Curtain



SIZE: ALL SIZES

This transformer piece can be worn as a ruffle skirt or a wedding gown

INTRODUCTION

The Dress-Skirt presented in the photos was sewn from an old granny's curtain which had been lying in my mom's and then in my own closet for a few decades. Unused, not only due to its size that didn't fit a single window, but also because of a few yellow stains on it, I decided to transform it into a skirt which can be converted to a dress. I came up with this idea since I couldn't make up my mind whether I wished the curtain be turned into a dress or a layered ruffle skirt, which I'd wanted to possess for quite some time. After a couple of days of changing my mind every minute, I had an epiphany – lift up the first ruffle up to the shoulders and create a transformer Dress-Skirt. Instead of shoulder seams the dress is kept in place by attaching 2 flower broaches, which adds to an even more romantic, vintage look. Therefore, the lavish old-fashioned lacy dress resembles a wedding gown.

Dress-Skirt consists of 5 ruffles sewn onto lining fabric one beneath the other, and it has elastic band sewn onto the waist.

When the 1st ruffle is lifted to form a dress, there are openings formed for arms to be pulled through. Even though there is extra material beneath the arms, the looseness and fluffiness of this model allows it, so the excess fabric falls softly under the arms and doesn't spoil the overall style of the dress.

DIFFICULTY LEVEL, SKILLS, TECHNIQUES

To make this Dress-Skirt, you will need basic knowledge of sewing. A special technique needed for this project is being able to gather the material and as such to sew it onto the lining.

MATERIALS

- A piece of white lace fabric which has the same right and wrong sides, 1.5 m (1.9 yds) in length and 210 cm (2.3 yds) in width, or an old curtain of the same dimensions
- A piece of white cotton fabric for lining, in the length from your waist to your ankles, and 140 cm (1.6 yds) in width
- Scissors, needle and thread
- Elastic band, 2 cm wide
- Sewing machine
- 2 broaches in the shape of a flower

SIZE INFORMATION

The length of the skirt is 107 cm (42 in)
The waist measurement is adjustable to every size

DRAWING/SCHEMATIC

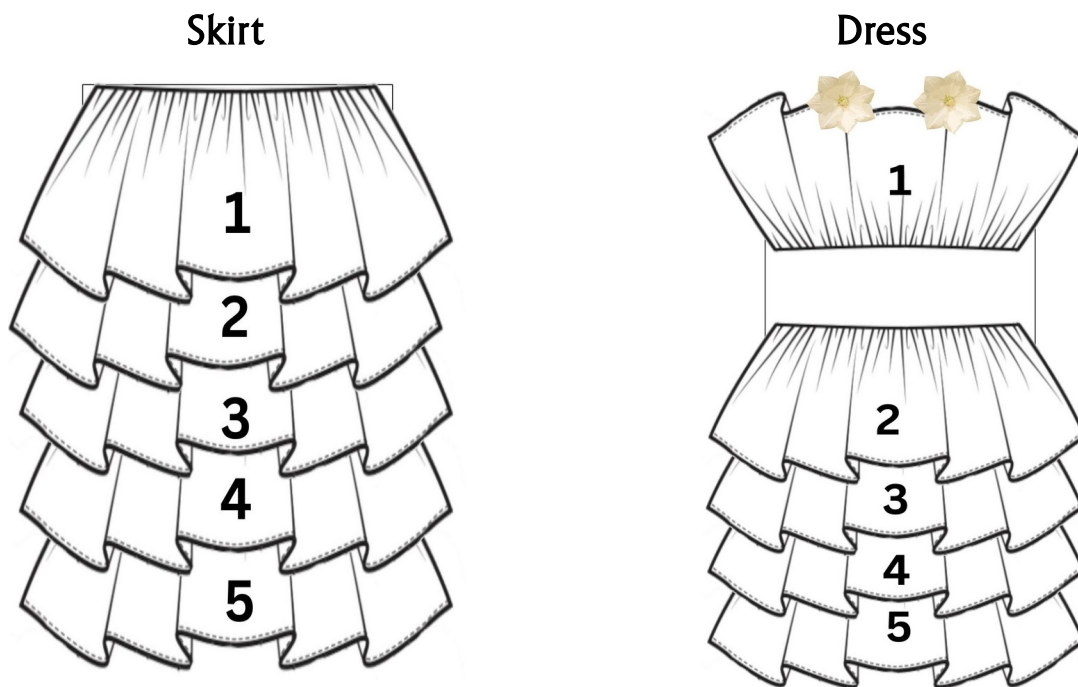

INSTRUCTIONS

Step 1

First, cut your lace/curtain in 5 stripes of the width as it originally is – 210 cm (2.3 yds), and the length as follows:

- 1 stripe 45 cm long (17.7 in)
- 2 stripes 30 cm long (11.8 in)
- 1 stripe 25 cm long (9.8 in)
- 1 stripe 20 cm long (7.8 in)

The diagram on the right shows the measurements and the direction of cutting the lace/curtain fabric.

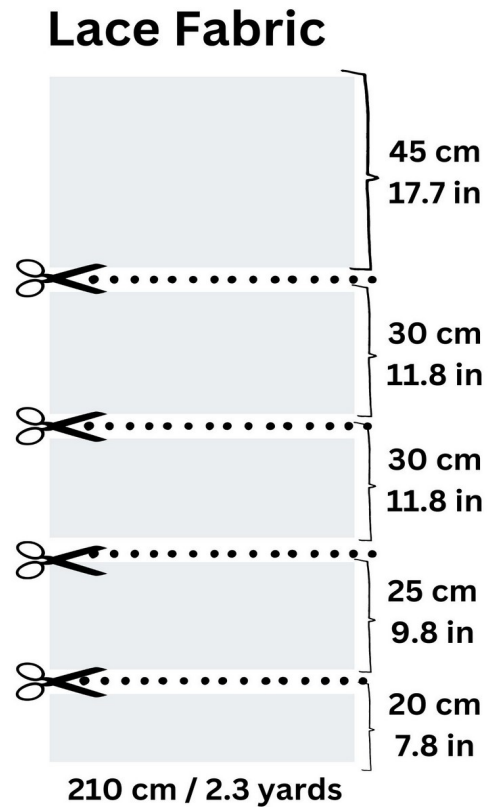

Step 2

Next, fold each lower side of all the ruffles 2 times onto the wrong side and stitch them to get a nice hem. Then gather every upper side of each ruffle to match the width of the lining material, i.e. 140 cm (1.6 yds). Each ruffle should look like this:

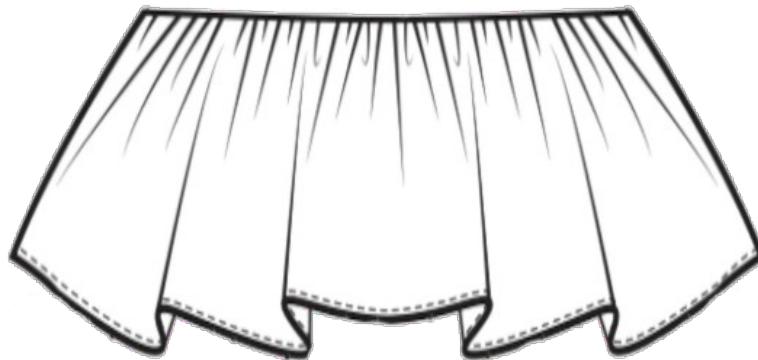

Step 3

On the lining fabric draw 4 horizontal and parallel lines on which you will be sewing the ruffles.

The 1st ruffle will be sewn on the upper edge.

The second ruffle goes 34 cm (13.4 in) below the upper edge.

The 3rd ruffle should be placed 15 cm (5.9 in) below the second.

The 4th ruffle is 19 cm (7.5 in) below the 3rd one.

The 5th ruffle is 17 cm (6.7 in) below the 4th ruffle.

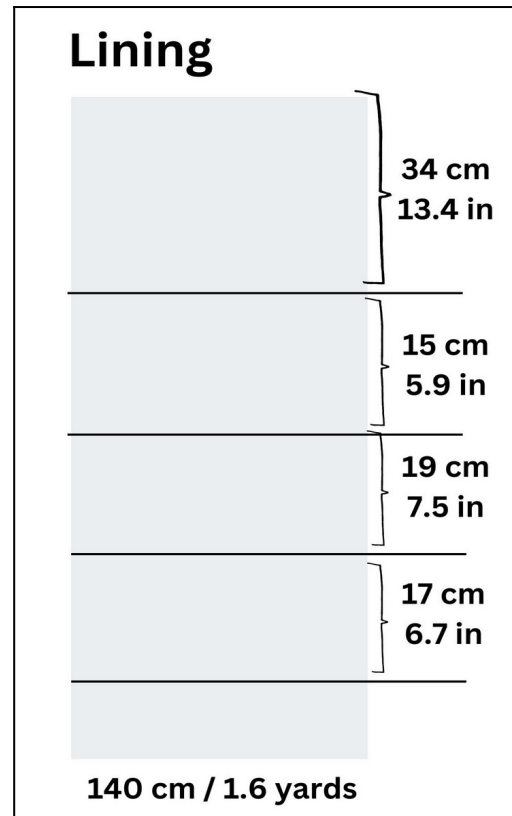

Step 4

Place the first ruffle onto the lining fabric, aligning its top edge with the top edge of the lining fabric. Pin or baste the top edge of the ruffle to the top edge of the lining and stitch down using a zigzag stitch on your sewing machine. See diagram on the right. Number 1 on the diagram represents the 1st ruffle.

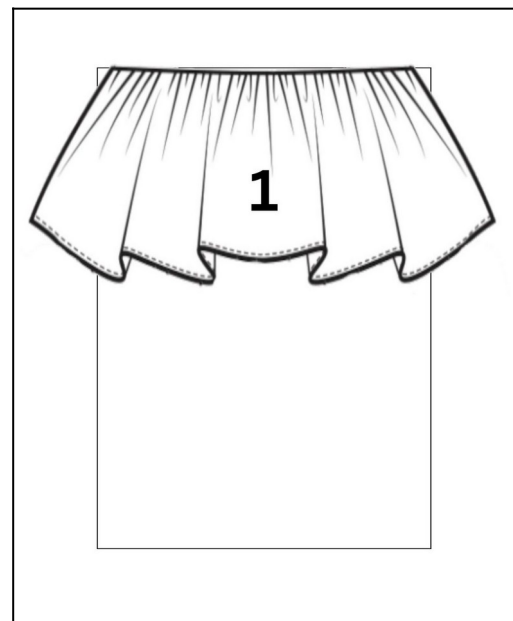

Step 5

Now lift the first ruffle up to make room for the next ruffle, and lay the second ruffle on the next parallel line – 34 cm (17.7 in) below the top edge. See 2 diagrams below, the image on the left shows the 1st ruffle lifted up and the 2nd ruffle sewn below. The image on the right shows what the work looks like when two ruffles are in their normal position.

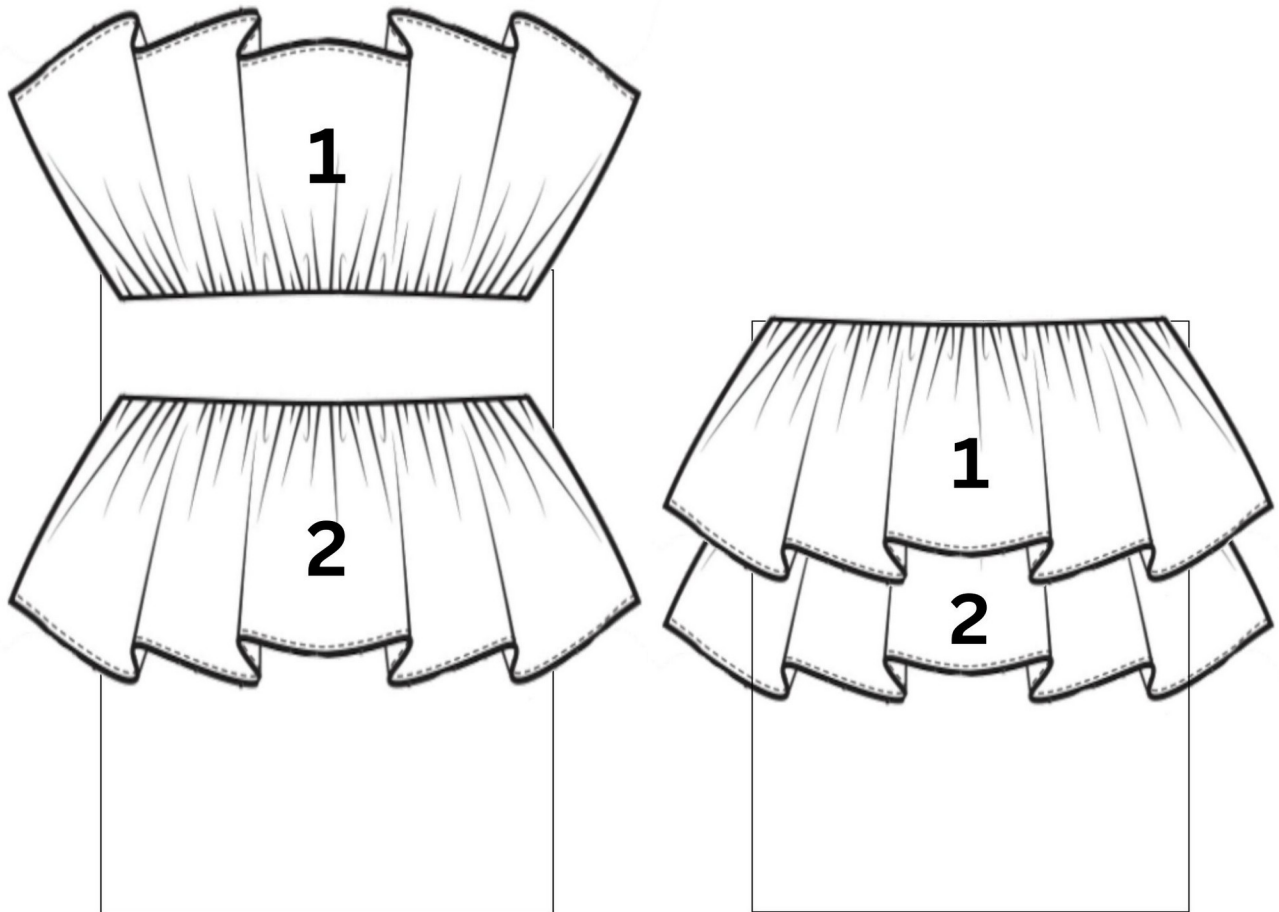

Step 6

Lift both sewn ruffles up to make space for the next one and place the 3rd ruffle on the next parallel line. Pin or baste it onto the lining and stitch down. The image on the left below shows the 1st and 2nd ruffles lifted up, while the 3rd ruffle is sewn below them. The image on the right represents the normal position of the ruffles.

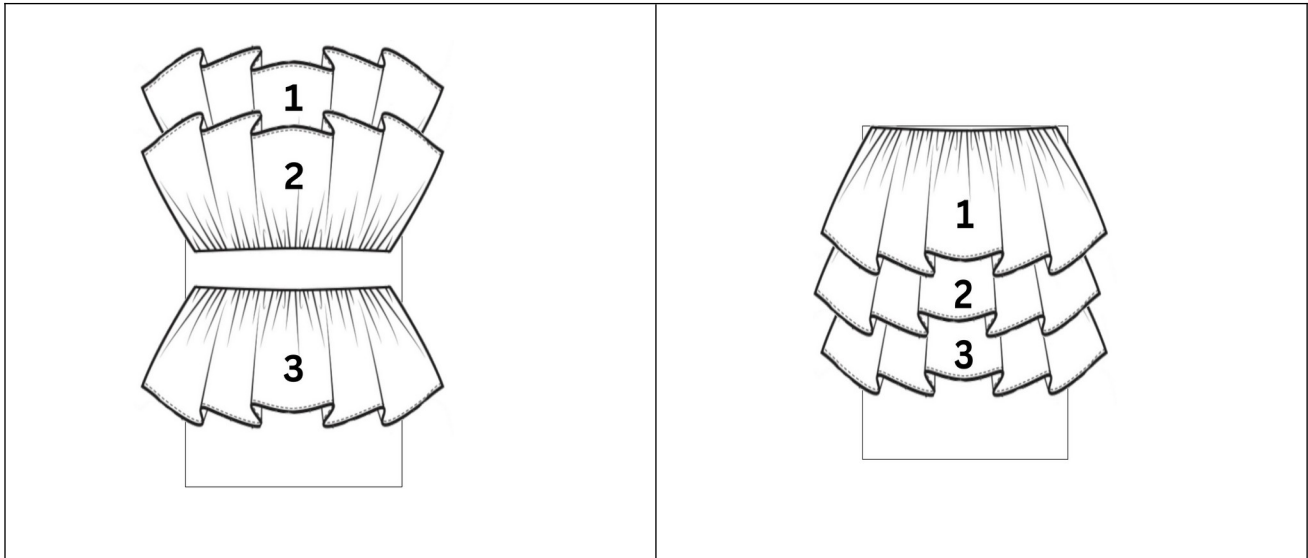

Step 7

Repeat the process of sewing the remaining 2 ruffles onto the lining. See images below.

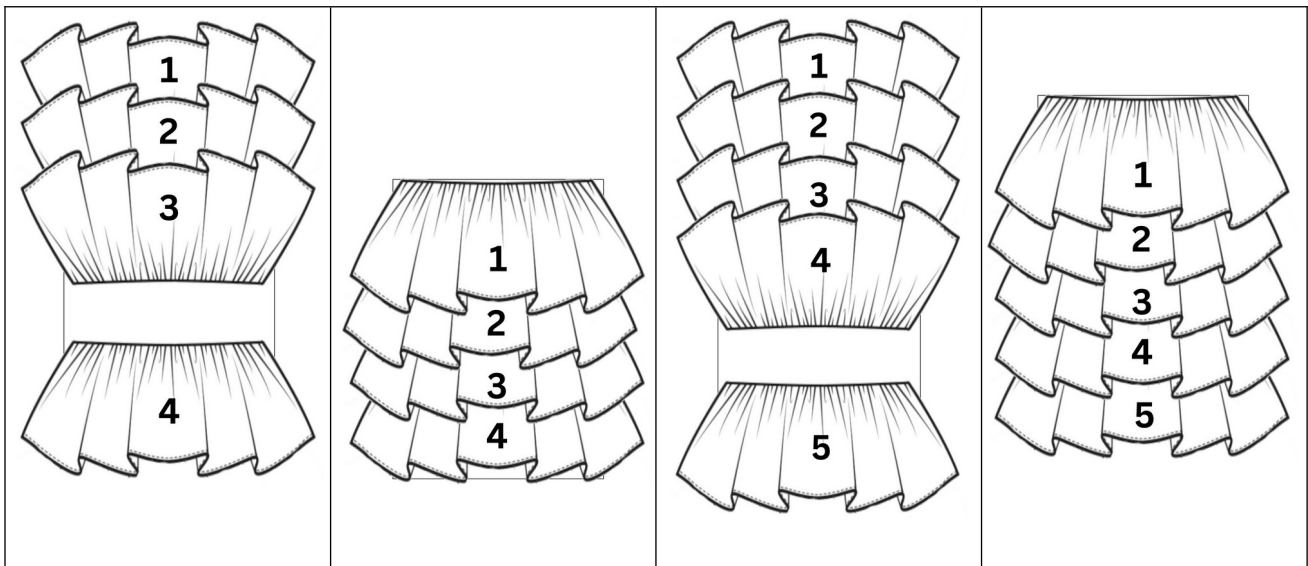

Step 8

When you have finished sewing all the ruffles onto the lining, pin down or baste the back seam of the skirt. Make sure to line up all top and bottom edges of every ruffle. Then stitch along the back seam. Press the seam open and work on its edges with a zigzag stitch to prevent fraying of fabric.

Now you can sew the elastic band on the upper edge of the skirt. Using a zigzag stitch sew the elastic band on its upper side.

FINISHING

If you leave all ruffles hanging down, you will have a skirt. However, when you lift the 1st ruffle up, the skirt transforms into a dress. Use 2 flower broaches to join back and front pieces on shoulders. Pull your arms through openings that will form in that process and voila! You're ready to get married! The lacy texture of the fabric makes the dress look like a wedding dress.

EXTRA TIP

You can sew an extra ruffle over the 1st one which is on top of the skirt-dress. That way, when the 1st ruffle is lifted up to form a dress, there will be another ruffle covering the lining fabric.

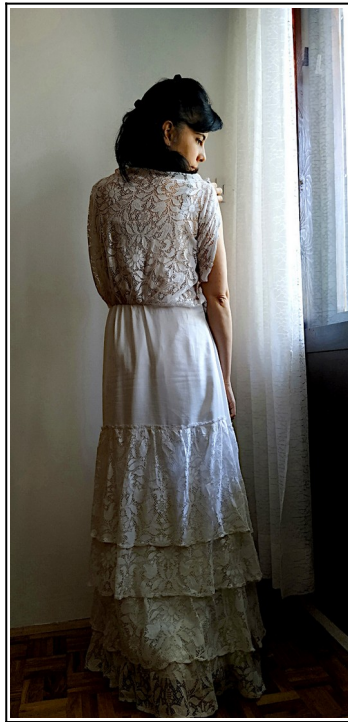

NOTE FROM THE DESIGNER

This pattern is for personal use only. Any unauthorized copying or selling of the pattern is not allowed.

If you publish your version of [Dress-Skirt](#), please state me as the creator of the pattern.

I would appreciate any form of feedback to do with the clarity of these instructions, as well as any mistakes you may come across while making this garment.

Should you have any comments, questions, or need help making this piece, please write to me to:
krpenalutkica77@gmail.com



You will also find me here:

[Ravelry Pattern Store](#)

[Love Crafts Store](#)

[Pinterest](#)

[Instagram](#)

[Facebook page](#)

[You Tube channel](#)

Thank you for downloading this pattern and for your support!

Happy Sewing!

©Jelena Mitić, January 2022.

krpenalutkica.com